

- HOSEBED**
- 250' OF 2-1/2"
 - 2,000' OF 4"
 - 500' OF 2-1/2"
 - 250' OF 2-1/2" HIGH RISE
 - (2) PIKE POLE CHUTES
 - (1) BACKBOARD STOR
 - (1) 10' FOLD

- LADDER BRACKETS**
- (1) 24' 2-SECT
 - (1) 14' ROOF

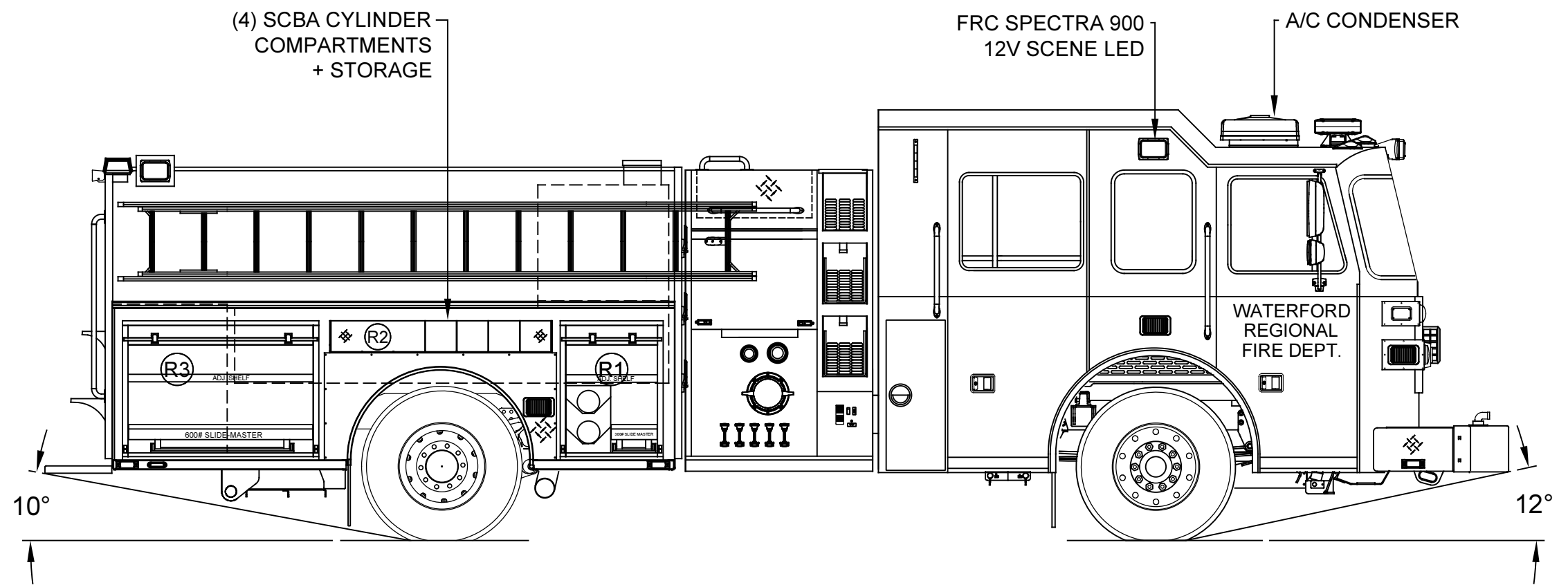

LEFT SIDE COMPARTMENTS				
COMPT	DOORS	OPENING DIMENSIONS	INSIDE DIMENSIONS	VOLUME
L1	ROLL-UP	25.5"w X 63.4"h	30.5"w X 72"h X 27.3"d	34.7 CU. FT.
L2	ROLL-UP	57.5"w X 34.2"h	61.6"w X 42.8"h X 27.3"d	41.7 CU. FT.
L3	ROLL-UP	50.5"w X 63.4"h	53.4"w X 72"h X 27.3"d	60.7 CU. FT.

RIGHT SIDE COMPARTMENTS				
COMPT	DOORS	OPENING DIMENSIONS	INSIDE DIMENSIONS	VOLUME
R1	ROLL-UP	25.5"w X 51.4"h	30.5"w X 40"h X 27.3"d	19.3 CU. FT.
R2	DROP DOWN	57"w X 7.3"h	59"w X 8.5"h X 28.5"d	8.3 CU. FT.
R3	ROLL-UP	50.5"w X 51.4"h	53.4"w X 40"h X 27.3"d	33.7 CU. FT.

REAR STEP COMPARTMENT				
COMPT	DOORS	OPENING DIMENSIONS	INSIDE DIMENSIONS	VOLUME
A1	ROLL-UP	37.5"w X 32.8"h	40"h X 40"w X 31"d	28.7 CU. FT.
TOTAL:				227.1 CU. FT.

TWO TONE CAB SPECIAL BREAK LINE
PAINT BREAK OPTION #3
GRAY OVER RED

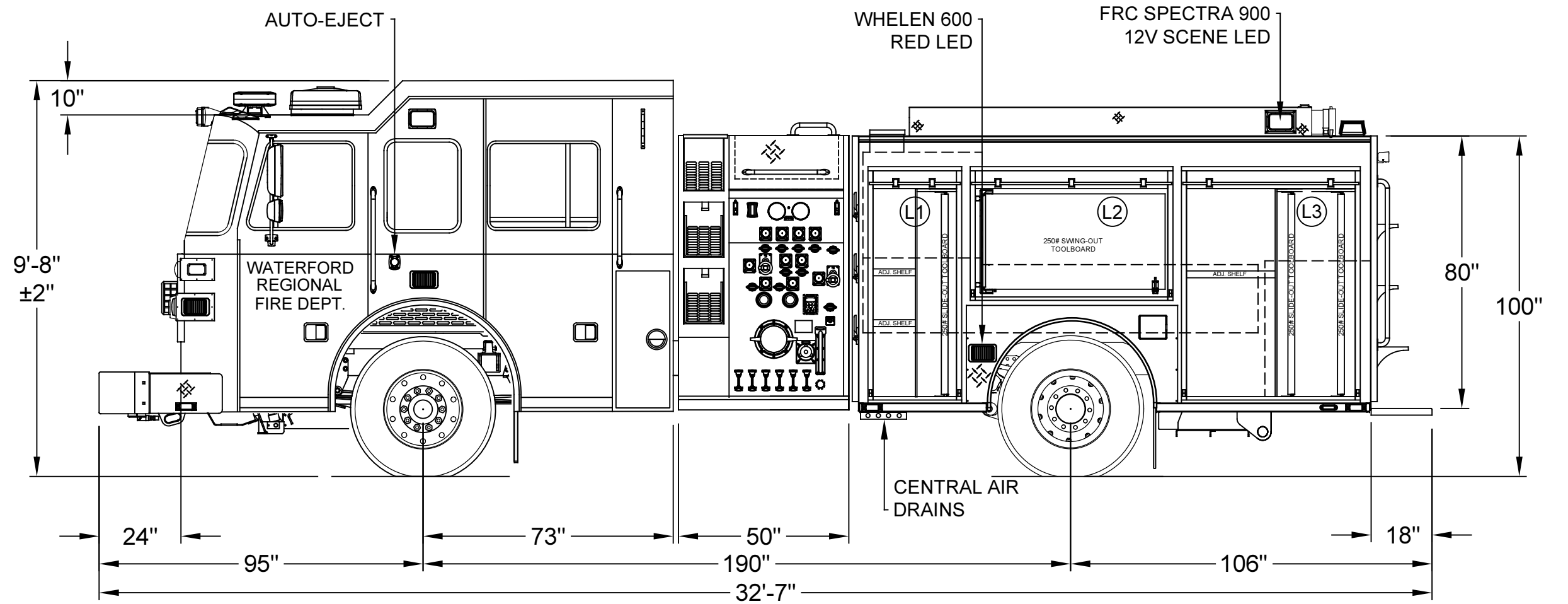
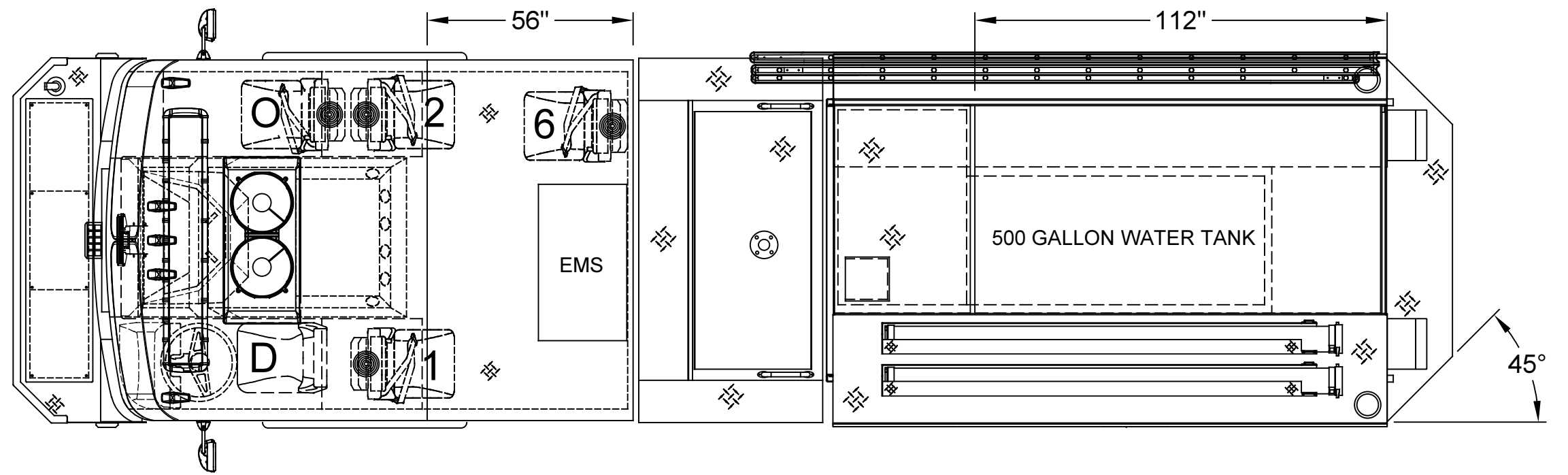
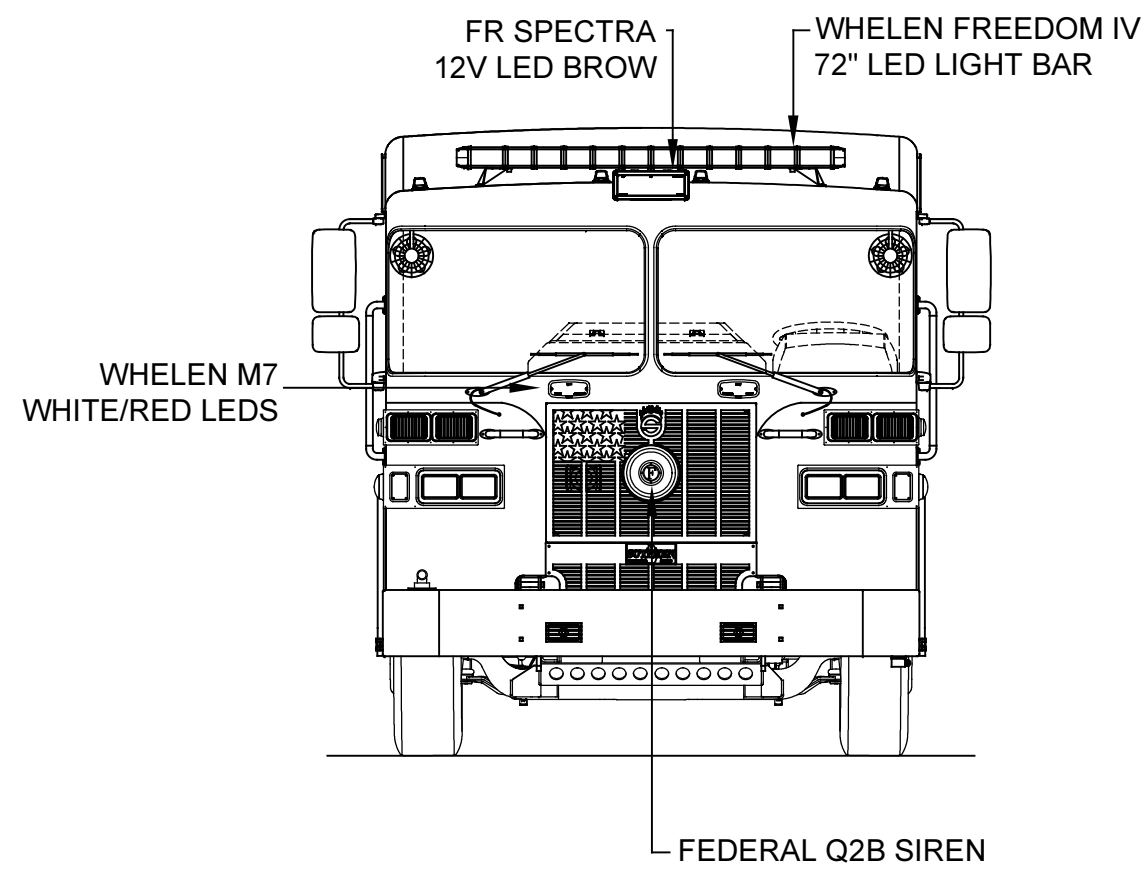

DIMENSIONS SHOWN ON THIS DRAWING ARE APPROXIMATE AND ARE SUBJECT TO MINOR DEVIATIONS DURING CONSTRUCTION.

IN THE EVENT OF A DISCREPANCY BETWEEN THE SUTPHEN SPECIFICATIONS AND DRAWING, THE SUTPHEN SPECIFICATIONS SHALL PREVAIL.

DRAWING IS FOR REFERENCE ONLY. SOME ITEMS PROPOSED MAY NOT BE SHOWN OR NOTED.

CUSTOMER APPROVAL

NAME: _____

TITLE: _____

DATE: _____

REV.	DESCRIPTION	BY	DATE

DRAWN BY:
T.FAHOUM

DATE:
12/23/21

MFG. FACILITY:
URBANA

WATERFORD REGIONAL FIRE DEPARTMENT
WATERFORD TOWNSHIP, MI

CUSTOM PUMPER - PA-11 BODY

DWG. NO.: HS-8155